

Amusement and Vending Industry

PT1648AFAV

Tailored for the vending industry, this strong, durable liftgate is designed for transporting vending machines. Our rail style, chain-driven liftgate with a non-arcing level ride, will provide many years of reliable rugged service.



Model Shown PT1648AFAV

Key Features

- Large 48" aluminum platform easily holds a vending machine
- Above-floor lift reaches a 46" high dock
- Large 12" ramp allows for easy pallet jack loading
- Rail style design offers maximum stability and reduces maintenance cost
- The PT Series is the premium light vehicle application liftgate
- **Lifting capacity** - 1,600 lbs.
- **Applications** - pickup trucks, trailers, straight trucks, flatbeds and rack bodies



Optional all aluminum PT liftgate shown

Call 800-289-1335 in the U.S.
416-421-7987 in Canada

Visit our web site: www.ultronlift.com

Amusement & Vending Industry Railgate Product Information

Clearance and Lift Dimensions

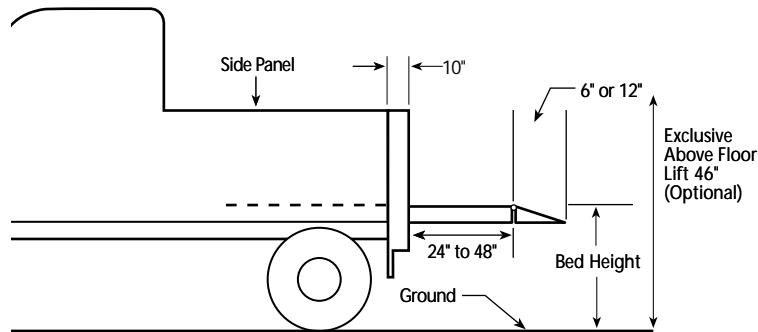
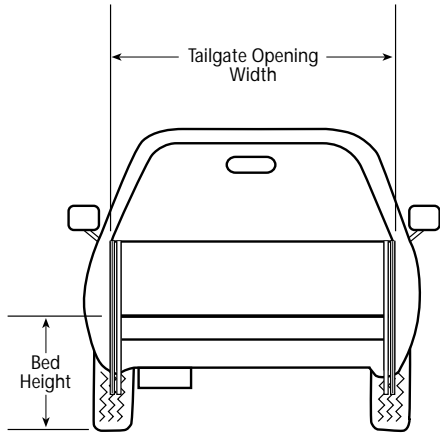

Specifications

Fits full-size vehicles; specify vehicle make, model and year when ordering

Model	Capacity lbs	Bed Height Min-Max"	Platform Area & Ramp"	Overall Rail Width"	Platform Material	Inside Opening"	Application Code**	Shipping Wt. (lbs)
PT1648AFV	1600	25-46	56 X 48 + 12	61	aluminum	56	A	380
PT126230	1200	25-37	57 X 30 + 6	61	steel	57	A	310
PT126230AF*	1200	25-46	57 X 30 + 6	61	steel	57	A	360
PT166230	1600	25-37	57 X 30 + 6	61	steel	57	A	320
PT166242	1600	25-37	57 X 42 + 6	61	steel	57	A	345
PT166230AF*	1600	25-46	57 X 42 + 6	61	steel	57	A	410
PT166242AF*	1600	25-46	57 X 30 + 6	61	steel	57	A	435
DL169448A	1600	32-56	57 X 42 + 6	94	aluminum	89	C, D, E	505
DL209448A	2000	32-56	89 X 48 + 6	94	aluminum	89	C, D, E	575
DL169448AFA*	1600	32-56	89 X 48 + 6	94	aluminum	89	C, D, E	565
DL209448AFA*	2000	32-56	89 X 48 + 6	94	aluminum	89	C, D, E	605

* AF denotes models with above-floor lift. Bed Height Maximum Minus Actual Truck Bed Height = Platform Lift Above Floor.

** Application Code : A -Pickup Trucks, B -Trailers, C -Straight Trucks, D -Flatbeds, E -Pickup Trucks
Aluminum platform available as an option on all models listed

Standard Features

- Three year warranty
- License recess
- Built-in toe deflector
- Master disconnect switch and 135 amp circuit breaker
- Level ride keeps your payloads level throughout the entire travel of the gate.
- Weather sealed electronic controls are easier and safer than mechanical controls
- Torsion bar assisted platform makes it easier to open and close
- Compact weight saving design increases payload and fuel efficiency
- Chain and sprocket drive eliminates the need for costly cable replacement

Popular Options

- AF- Above Floor Lifts higher than the floor of the truck
- Automatic Cart Stop Ramp is 12" instead of 6" and acts as cart stop
- Non-Standard Width Cut overall rail width down to your body dimension
- Non-Standard Depth added in 6" increments
- Remote Toggle Switch Control
- Power Open/Close
- Low Maintenance ValuPak
- Hinged 12" Aluminum Ramp



Authorized Distributor

E-mail: info@ultronlift.com • Web: www.ultronlift.com

Ultron Lift Corp.
190 Lewis Street • PO Box 6126
Buffalo, NY 14240-6126 USA
Phone: 800-289-1335
716-853-7994
Fax: 716-854-5424

Ultron Lift Inc.
Les Hayons Ultron Inc.
12 Industrial Street
Toronto, ON M4G 1Y9 Canada
Phone: 416-421-7987
Fax: 416-421-7927