

515

MODELLI MODELS	MOMENTO LIFTING MOMENT	SBRACCIO ORIZ. HORIZ. HYDRAULIC OUTREACH	PORTATA AL DISTRIBUTORE OIL FLOW TO THE CONTROL VALVE	SBRACCIO MAX. VERTICALE MAX VERTICAL REACH	PESO WEIGHT	PRESSIONE PRESSURE	INTERASSE STABILIZZATORI STANDARD APERTI DISTANCE BETWEEN CENTRES WITH OPENED OUTRIGGERS
	Tm.	m.	l.min	m.	Kg	bar	mm.
515A1	1.40	4.55	8	6.56	290	180	2550

Autocarro consigliato - Recommended truck - Camion conseillé - Camion aconsejado
M.T.T. ton 2 - G.V.W. ton 2

STANDARD



370°
Angolo di rotazione
Slewing angle



120
Serbatoio olio
Oil Tank

515 A1

m	2.00	3.20	4.55	5.90
Kg	700	435	300	200

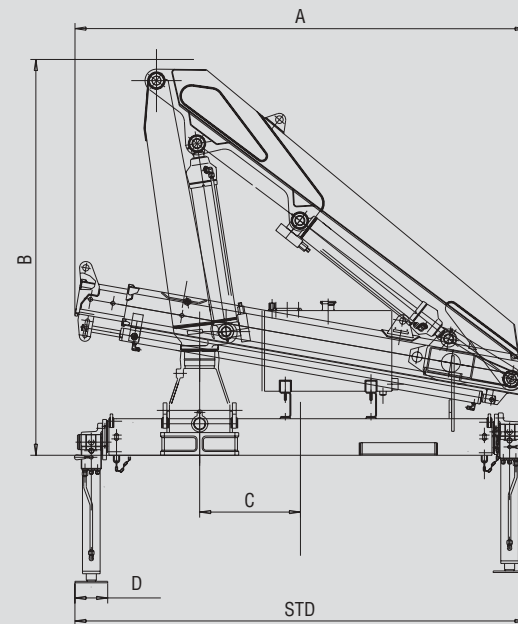

515	A	B	C	STD	EXT	XXL	D
515A1	1783	1489	423	1785	-	-	130

SPAZIO RICHiesto PER L'INSTALLAZIONE NECESSARY SPACE FOR INSTALLATION

515	STD	XXL	con attivazioni	STD	XXL
515A1	450	-	With extra function 540	-	-



F.lli FERRARI CORPORATION S.p.A.

Via Pasubio, 3

42022 Boretto (RE) Italy

Tel. +39 0522/ 964921

Fax +39 0522/964405

E-mail:marketing@fliferrari.it

COMPANY
WITH QUALITY SYSTEM
CERTIFIED BY DNV

Dati, descrizioni e illustrazioni sono indicativi e non impegnano F.lli Ferrari. Gru prodotte e/o commercializzate da F.lli Ferrari - Data, descriptions and illustrations are merely indicative and not binding. Cranes manufactured and marketed by F.lli Ferrari - Les données, descriptions et illustrations sont uniquement indicatives et n'engagent pas F.lli Ferrari. Grues produites et/ou vendues par F.lli Ferrari - Angaben, Beschreibungen und Abbildungen sind weisend und verpflichten nicht F.lli Ferrari. Die Kräne werden von F.lli Ferrari hergestellt und/oder vermarktet - Los datos, las descripciones y las ilustraciones son indicativos y no implican compromiso para F.lli Ferrari. Gruas producidas y/o comercializadas por F.lli Ferrari - Os dados as descrições e ilustrações são indicativos e não comprometem F.lli Ferrari. Guindaste produzidos e/ou comercializados pela F.lli Ferrari.

M.K.T. 5600096 03/04 3000





F.LLI FERRARI CORPORATION S.p.A.

FERRARI 515



①

La gru F.Ili Ferrari mod. 515 racchiude in se caratteristiche tecniche e meccaniche di elevata qualità

- Acciai ad alto limite di snervamento
- Basamento e pignone colonna in fusione
- Struttura interamente sabbiata
- Bracci esagonali
- Sbracci fino a 4.55 m (5.9 con prolunga meccanica)
- Valvole di sicurezza flangiate
- Stabilizzatori rotanti
- Pattini di scorrimento con ripresa gioco autoserrante
- Boccole autolubrificanti
- Raccordo SAE J 1514I
- Gancio girevole
- Kit di montaggio compreso

Accessori

- Prolunghe meccaniche
- Traverse supplementari
- Comando supplementare attivato
- Utilizzo con attrezzo
- Versione elettrica
- Limitatore di momento
- Dispositivo di controllo RLC
- Comandi bilaterali

GB

The crane model 515 from F.Ili Ferrari has been projected and manufactured with high quality technical and mechanical characteristics

- Steel at high yielding edge
- Basement and column pinion by melding made
- Structure fully sandblasted
- Hexagonal booms
- Hydraulic outreach until 4.55 mt (5.09 with mechanical boom)
- Flanged valves
- Turning outriggers
- Sliding pad with self-adjusting gap
- Self-tapping bushings
- SAE JIC 1514I fittings
- Turning hook
- Mounting kit included

Accessories

- Mechanical booms
- Extra beams
- Extra activated element
- Hydraulic winch
- Electrical version
- Load limiting device
- Load radio checking device RLC
- Bilateral controls

F

LA grue modèle 515 F.Ili Ferrari est conçue avec des caractéristiques techniques et mécaniques de plus haute qualité

- Acier à haut niveau de déformation plastique
- Embase et pignon colonne moulés
- Structure complètement sablée
- Rallonges hexagonales
- Portée Hydraulique jusqu'à 4.55 Mt (5.9 mt avec rallonges mécaniques)
- Vannes bridées
- Béquilles tournantes
- Patins de coulissement auto enregistrables
- Douilles autolubrifiantes
- Raccords SAE-JIC 1514I
- Crochet tournant
- Kit de montage inclus

Accessoires

- Rallonges mécaniques
- Poutres bâquilles supplémentaires
- Circuit supplémentaire activé
- Treuil hydraulique
- Version lectrique
- Limiteur de moment
- Dispositif de contrôle de la charge RLC
- Commandes bilatérales

D

Das Kranmodell 515 vom F.Ili Ferrari ist mit höchsten Qualität für technischen und mechanischen Eigenschaften projiziert und hergestellt worden

- Stahl am hohen einträglichen Rand
- Sockel und Zahnrad beim Schmelzen gemacht
- Struktur voll Sand gestrahlt
- Sechseckige Ausschube
- Hydraulischen Reichweiten bis 4.55 mt. (5.9 mt mit mechanischen Ausschube)
- Geflanscht Ventilen
- Drehbar Abstützungen
- Gleitschuh mit Selbstnachsteller Spiel
- Selbstschmierende Buchsen
- SAE-JIC 1514I Anschlusse
- Schwenkbar Haken
- Einsatzbau eingeschlossen

Zubehöre

- Mechanische Ausschube
- Zusatzabstützungen
- Be tigt Zusatzfunktion
- Hydraulischer Winde
- Elektrische Auführung
- Lasthaltventil
- Gewichtskontrolle Vorrichtung RLC
- Zweiseitige Kontrollen

SP

El modelo de la grúa 515 de F.Ili Ferrari se ha proyectado y fabricado con características técnicas y mecánicas de alta calidad

- Acero en el alto borde de rendimiento
- Piñón de la columna y basamento moldeados
- Estructura completamente arenada
- Prolongas hexagonales
- Alcances hidraulicos hasta mt. 4.55 (5.9 mt con prolongas mecanicas)
- Valvulas rebordeadas
- Patas giratorias
- Patín de deslizamiento con juego autoregurable
- Casquillos autolubricantes
- Empalmes SAE-JIC 1514I
- Gancho giratorio
- Kit de montaje incluido

Acesorios

- Prolongas mecánicas
- Patas adicionales
- Activacion adicional
- Cabrestante hidraulico
- Version electrica
- Limitador de momento
- Dispositivo de verificacion de carga RLC
- Mandos bilaterales

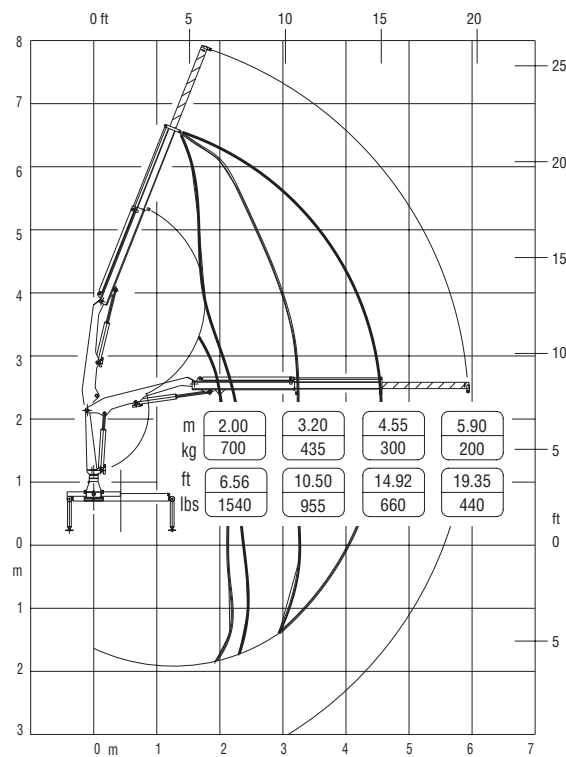

Questo dispositivo visualizza su un display collocato in prossimità dei comandi il carico applicato al gancio della gru, rendendo l'utilizzo delle prolunge meccaniche sicuro secondo la normativa europea EN 12999.

This device shows the load at the hook on a display placed near the controls, making safe the use of the mechanical booms following the European rule EN 12999.

