

Ultron

Rail Style Liftgates

Heavy Duty HD Series™

Advanced dock protection
minimizes possible damage
caused by normal dock impact
This reduces downtime,
allowing your truck(s) to
remain on the road.



Key Features

- Chain and sprocket drive reduces downtime caused by frayed or broken cables
- Platform folds in half, allowing direct access for dock loading on lower bed heights
- Lighter design than cable and direct lift allows you to carry more payload
- Extra reinforced platform reduces damage caused by heavy loads
- Heavy duty sliders offer strength and durability for increased cycling
- **Lifting capacity** - 2,000 - 8,000 lbs.
- **Applications** - straight truck, flatbeds and trailers



Call 800-289-1335 in the U.S.
416-421-7987 in Canada

Visit our web site: www.ultronlift.com

Heavy Duty Railgate Product Information

Clearance and Lift Dimensions

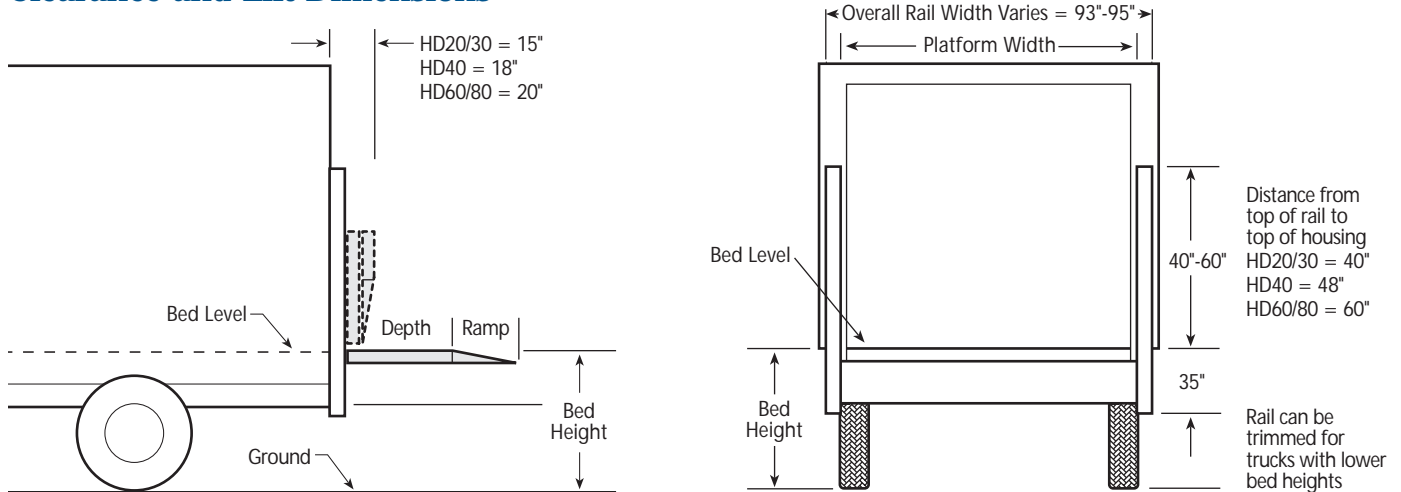

Specifications

Model	Bed Height Min-Max"	Capacity lbs.	Min Wt. lbs.	Overall Rail width"	Available Platform Sizes			Std Hyd Power Open & Close
					width"	depths"	ramp"	
HD20	30-57	2000	975	94	89	36, 42	6	
HD20F*	36-57	2000	1075	93	86	48, 54	12	✓
HD30	30-57	3000	1050	94	89	36, 42	6	
HD30F*	36-57	3000	1310	93	86	48, 54	12	✓
HD40	30-57	4000	1210	95	89	36, 42	6	
HD40F*	40-57	4000	1230	95	88 or 89	42 or 60, 72	12	✓ (except 42" depth)
HD60	30-57	6000	1380	95	89	42	6	
HD60F*	40-57	6000	1960	95	89	60, 72	12	✓
HD80	40-57	8000	2100	94	89	42	6	✓
HD80F*	40-57	8000	2700	94	89	72	12	✓

* F denotes two piece folding platform

Popular Options

- Platform Material:
 - aluminum
 - galvanized steel
 - expanded metal
 - bar grating
- Oversized Ramp in aluminum or steel:
 - fixed • hinged
 - with cart stop
- Deeper, narrower or wider platforms
- Trailer wiring kits
- Battery boxes
- Above floor lift
- Remote hand held toggle switch control with 15 ft. coil cord

Standard Features

- Three year warranty
- Weight saving design
- Heavy duty motor
- Platform folds in half
- Built in safety toe deflector
- Same day parts service
- Weather sealed steel pump box fully encloses power unit
- Master disconnect switch and 135 amp circuit breaker
- Dual weather sealed electronic controls are easier and safer than mechanical controls.
- Meets TMC specifications
- Pressure compensated flow control valve controls platform descent regardless of load weight



Authorized Distributor

E-mail: info@ultronlift.com • Web: www.ultronlift.com

Ultron Lift Corp.
 190 Lewis Street • PO Box 6126
 Buffalo, NY 14240-6126 USA
 Phone: 800-289-1335
 716-853-7994
 Fax: 716-854-5424

Ultron Lift Inc.
Les Hayons Ultron Inc.
 12 Industrial Street
 Toronto, ON M4G 1Y9 Canada
 Phone: 416-421-7987
 Fax: 416-421-7927